

ZONE BALL VALVES



VZK Three-way Zone Valve

Zone ball valves intended for heating or solar thermal systems with water or antifreeze fluid and for systems with drinking water.

The valve is equipped with a **single-pole control** actuator. The actuator can be removed without removing the valve. The valve shall not be installed with the actuator downwards.

The valve requires Neutral, Permanent Live and Switched Live. The port B is open without Switched Live, as soon as Switched Live is present, the port A opens. The shift time is 64 s. The valve can be adjusted manually by turning the handle (after disconnecting the motor).

Technical Data

MAX. WORKING PRESSURE	16 bar
FLUID WORKING TEMPERATURE	up to 110 °C
MATERIALS	
VALVE BODY	forged brass, nickel plated
VALVE SPINDLE	chrome plated brass
VALVE BALL	chrome plated brass
O-RING	FPM
POWER CABLE	PVC
ACTUATOR	
VOLTAGE	230 V 50 Hz
POWER INPUT	9 W
CURRENT	40 mA
IP RATING	IP 44
PROTECTION CLASS BY EN 61 140 ed.2	II

Pressure drop

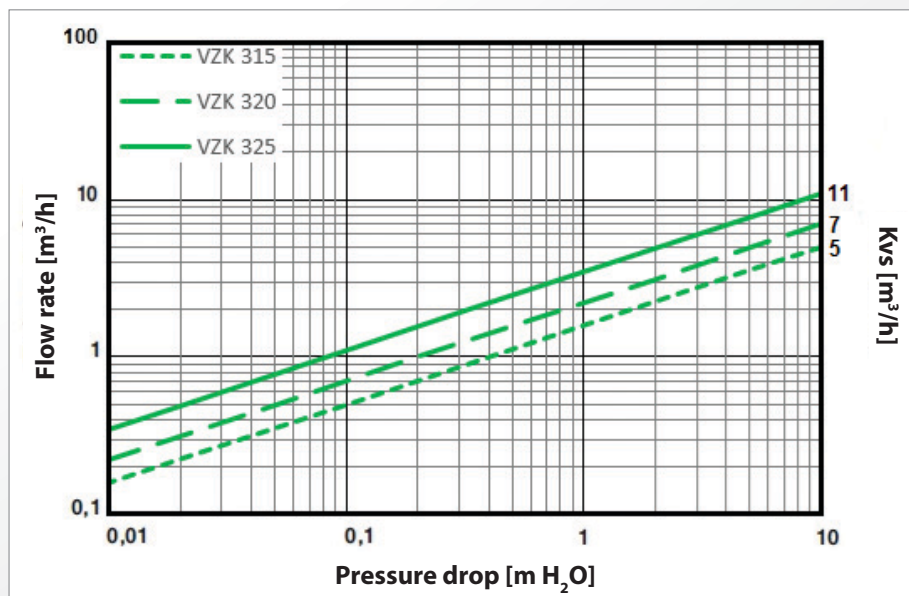

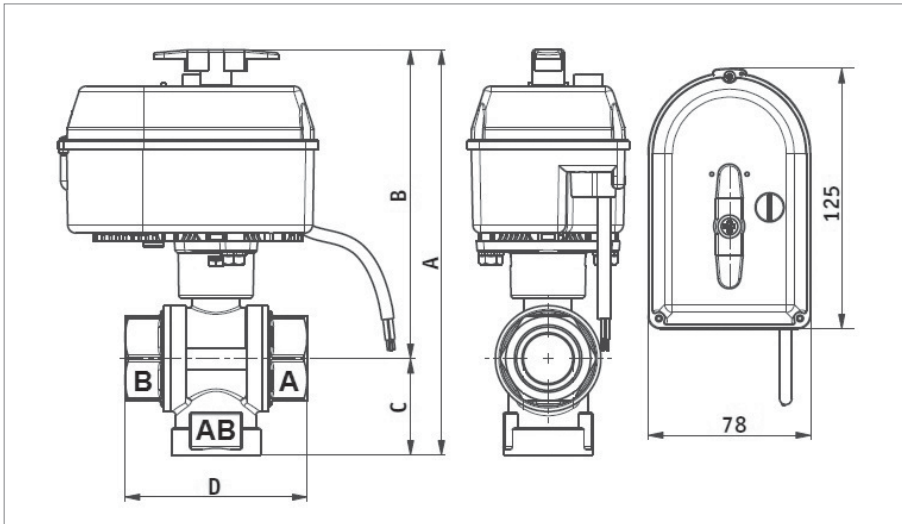

		VZK 315 -230-1P	VZK 320 -230-1P	VZK 325 -230-1P
CONNECTION	--	1/2" F	3/4" F	1" F
A	mm	183	183	194
B	mm	144	144	148
C	mm	39	39	46
D	mm	74	74	88
WEIGHT	kg	1.02	1.25	1.53
MAX. PRESSURE DIFFERENCE IN EITHER DIRECTION	bar	10	10	10
Kvs	m ³ /h	5.0	7.0	11.0
CODE	--	11 292	11 293	11 294

Electric wiring

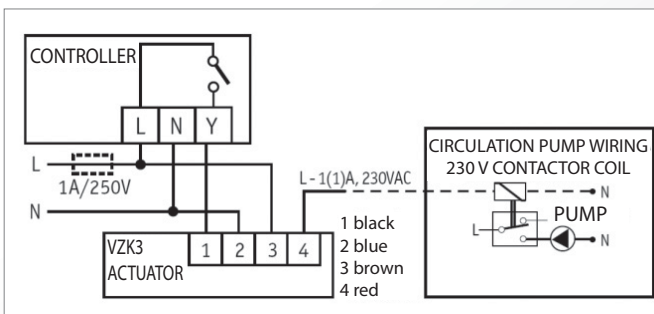

POWER CABLE

CROSS SECTION	4× 0.5 mm ²
LENGTH	2m

